

CSE 301

Combinatorial Optimization

Minimum Spanning Tree

Last Class's Topic

- Articulation Point

- How can we ensure that the root of the DFS tree is an articulation point?
- What does $LOW[v]$ mean?
- What's the way to calculate the $LOW[v]$ for any vertex? How can it be done by post order traversal?
- What is the criteria for a vertex to be an articulation point (except root)?

Problem: Laying Telephone Wire

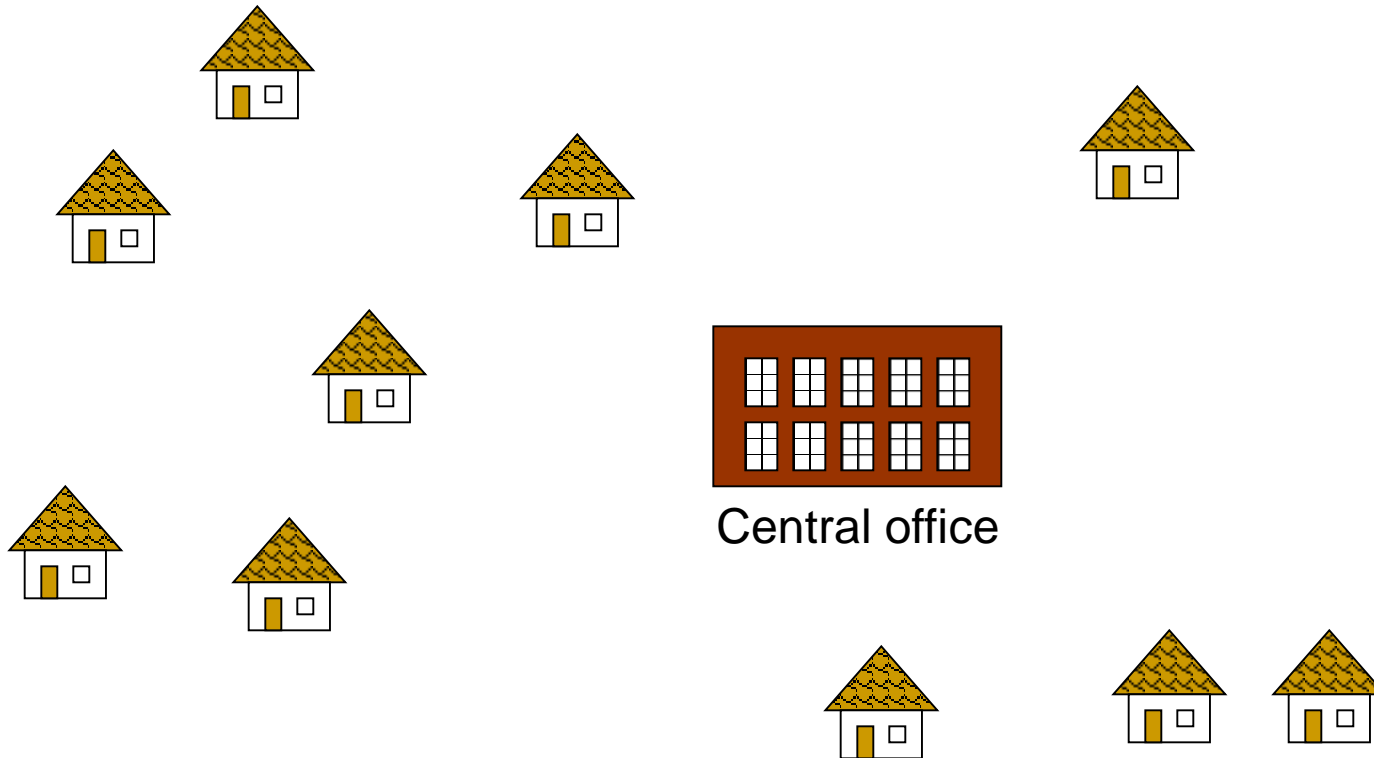

Wiring: Naïve Approach

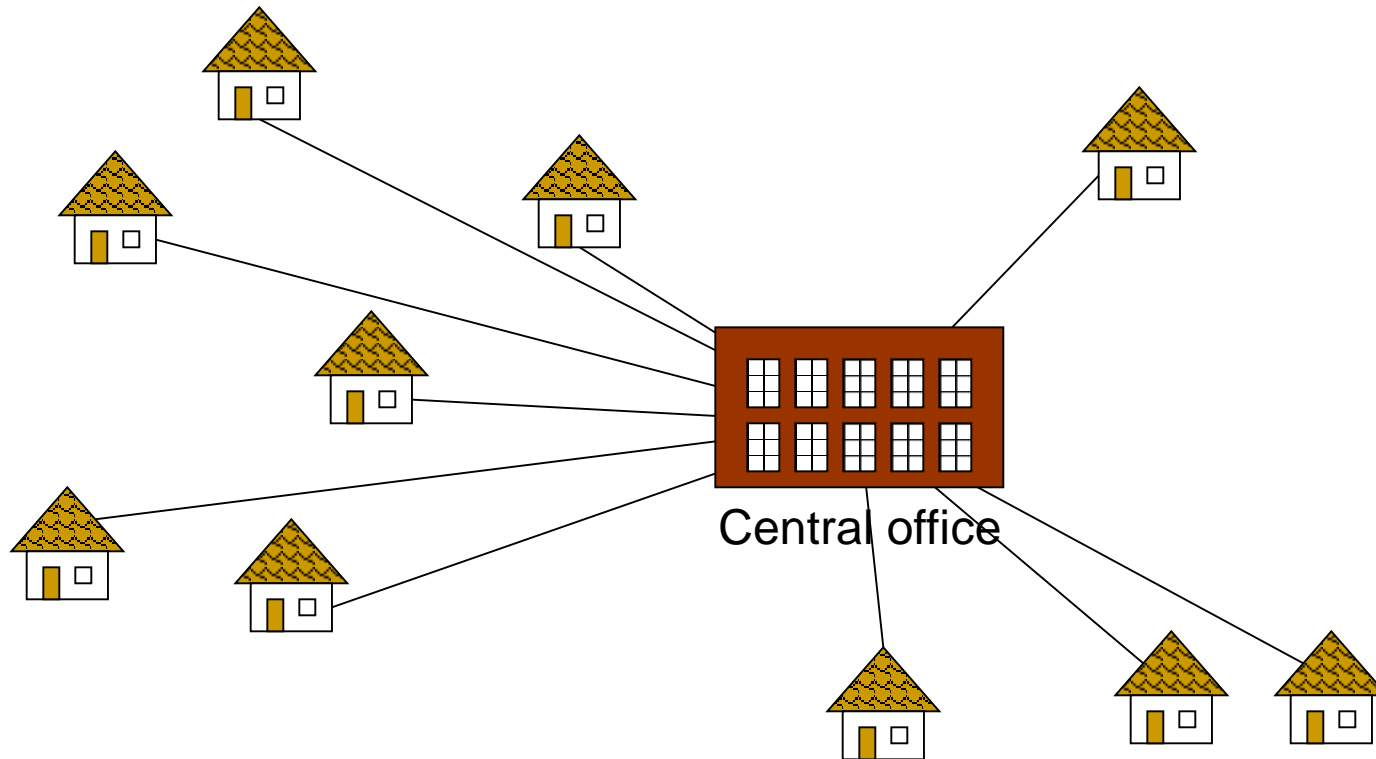

Expensive!

Wiring: Better Approach

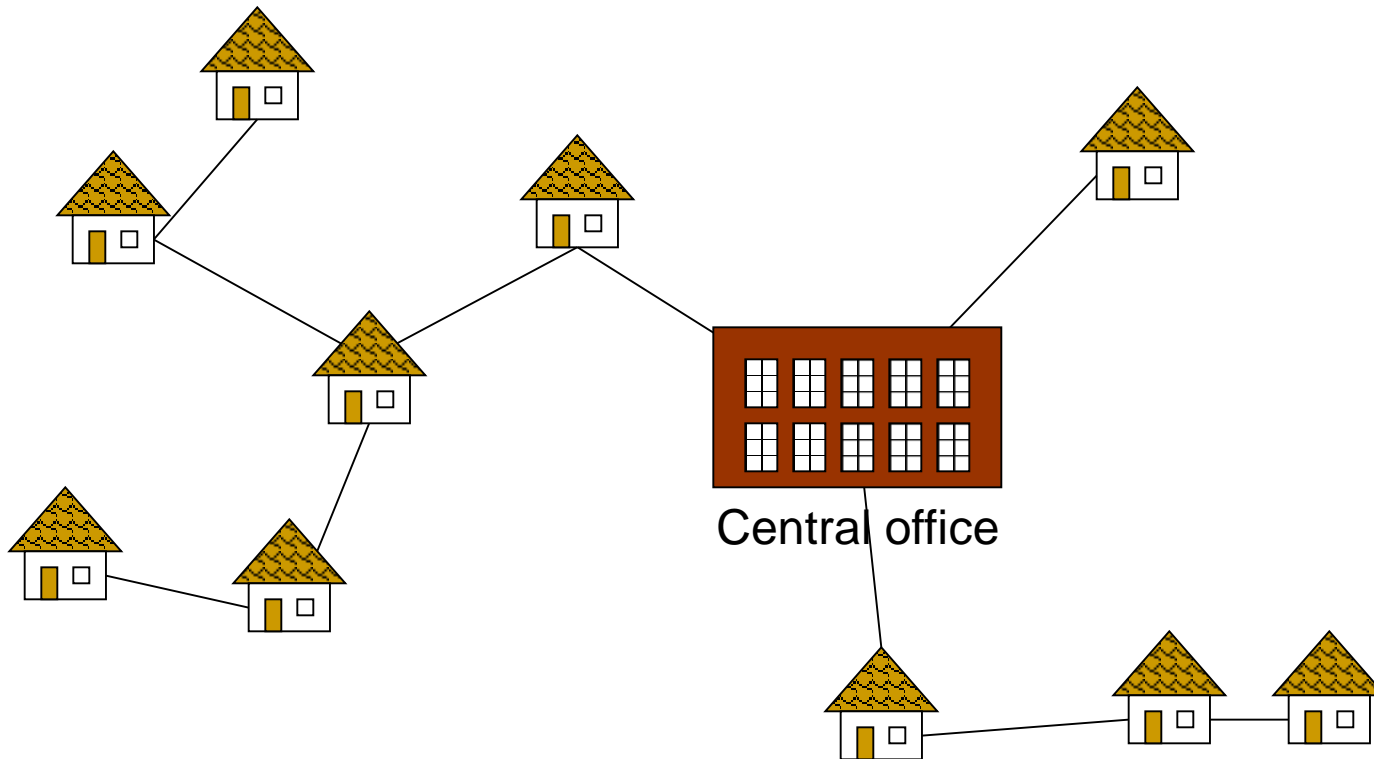

Minimize the total length of wire connecting the customers

A Networking Problem

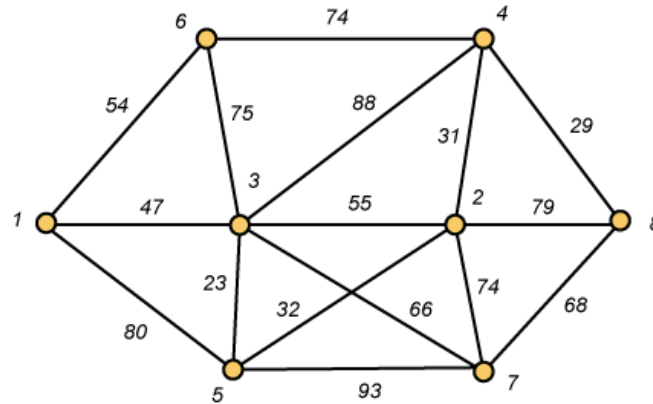

Problem: The vertices represent 8 regional data centers which need to be connected with high-speed data lines. Feasibility studies show that the links illustrated above are possible, and the cost in millions of dollars is shown next to the link. Which links should be constructed to enable full communication (with relays allowed) and keep the total cost minimal.

Links Will Form a Spanning Tree

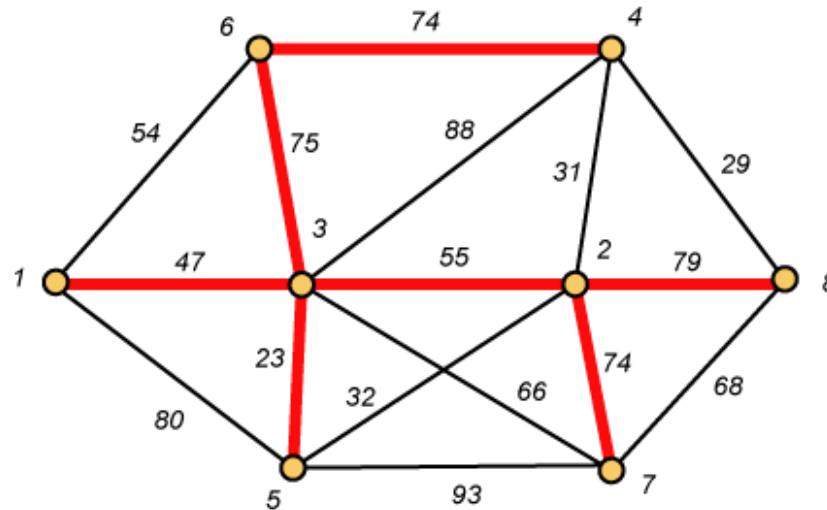

$$\begin{aligned}\text{Cost (T)} &= 47 + 23 + 75 + 74 + 55 + 74 + 79 \\ &= 427\end{aligned}$$

Minimum Spanning Trees

- Undirected, connected graph
 $G = (V, E)$
- Weight function $W: E \rightarrow R$
(assigning cost or length or other values to edges)

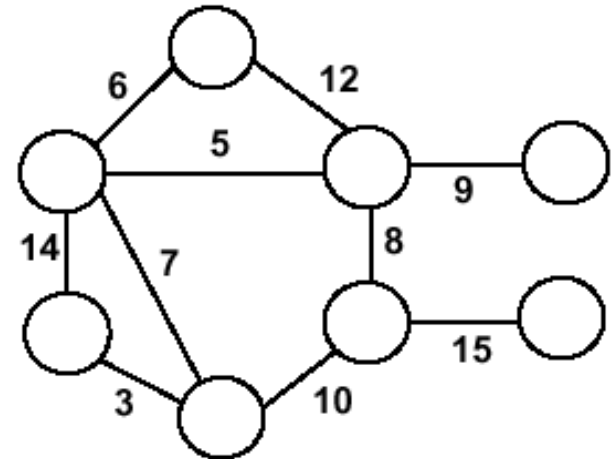

- Spanning tree: tree that connects all the vertices (above?)
- Minimum spanning tree: tree that connects all the vertices and minimizes

$$w(T) = \sum_{(u,v) \in T} w(u,v)$$

Minimum Spanning Tree (MST)

A **minimum spanning tree** is a subgraph of an undirected weighted graph G , such that

- it is a tree (i.e., it is acyclic)
- it covers all the vertices V
 - contains $|V| - 1$ edges
- the total cost associated with tree edges is the minimum among all possible spanning trees
- not necessarily unique

How Can We Generate a MST?

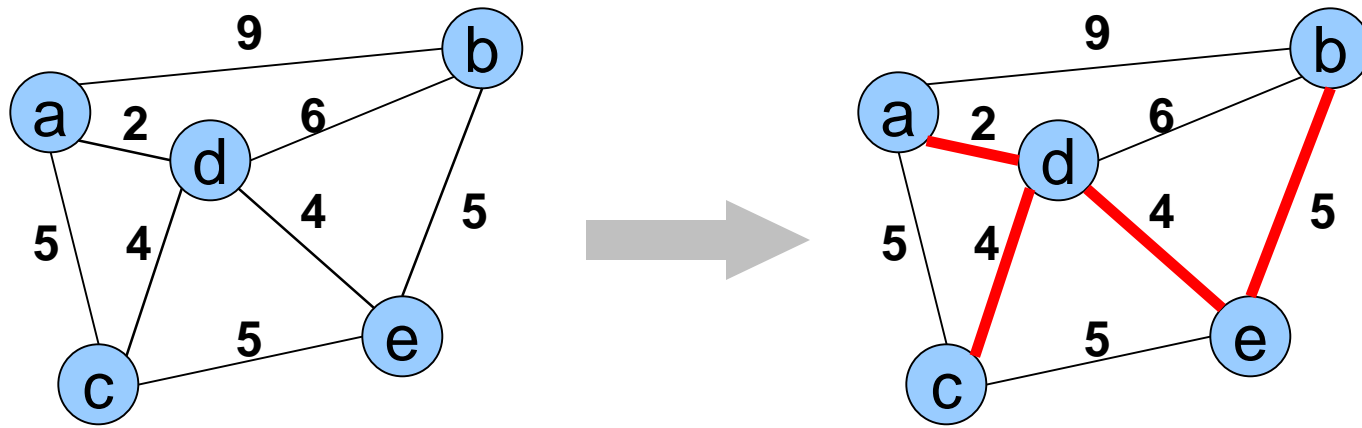

Greedy Choice

We will show two ways to build a minimum spanning tree.

- A MST can be grown from the current spanning tree by adding the nearest vertex and the edge connecting the nearest vertex to the MST. (Prim's algorithm)
- A MST can be grown from a forest of spanning trees by adding the smallest edge connecting two spanning trees. (Kruskal's algorithm)

Notation

- **Tree-vertices:** in the tree constructed so far
- **Non-tree vertices:** rest of vertices

Prim's Selection rule

- Select the minimum weight edge between a tree-node and a non-tree node and add to the tree

The Prim algorithm Main Idea

Select a vertex to be a tree-node

```
while (there are non-tree vertices) {  
    if there is no edge connecting a tree node  
    with a non-tree node  
        return "no spanning tree"  
  
    select an edge of minimum weight  
    between a tree node and a non-tree node  
  
    add the selected edge and its new vertex  
    to the tree  
}  
return tree
```

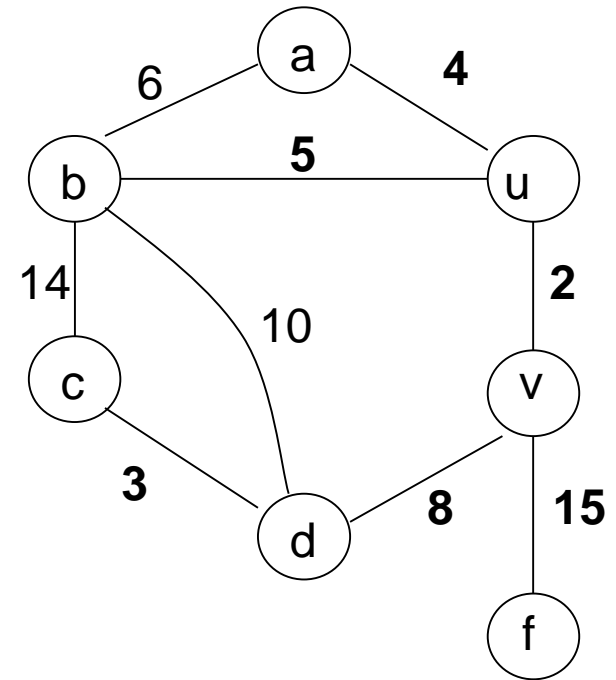

Prim's Algorithm

- Vertex based algorithm
- Grows one tree T , **one vertex at a time**

Prim – Step 1

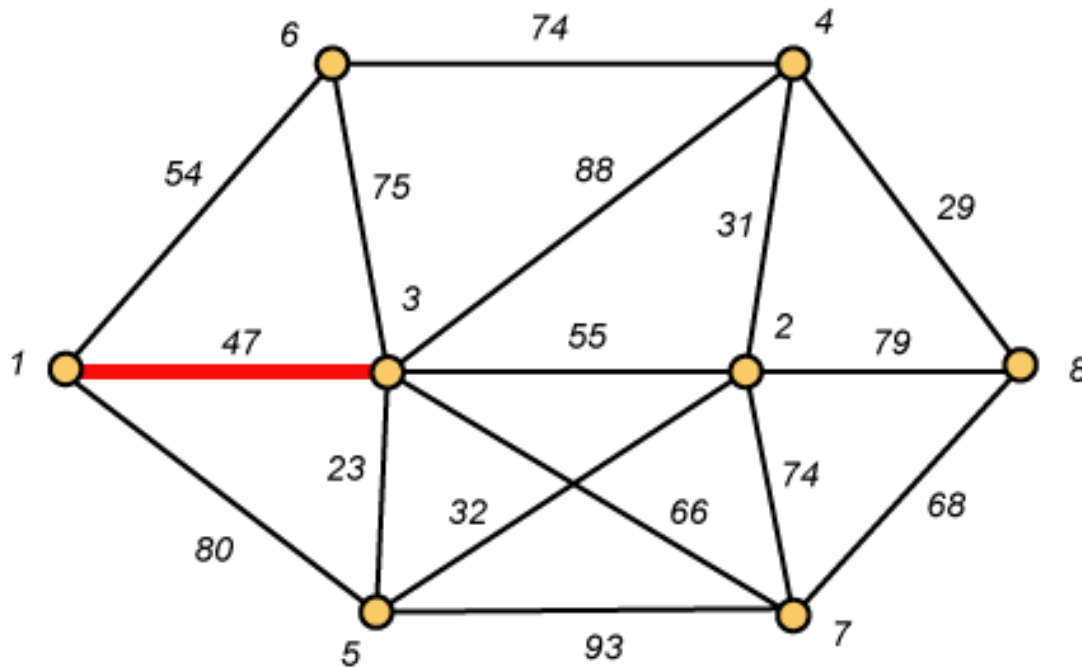

Prim – Step 2

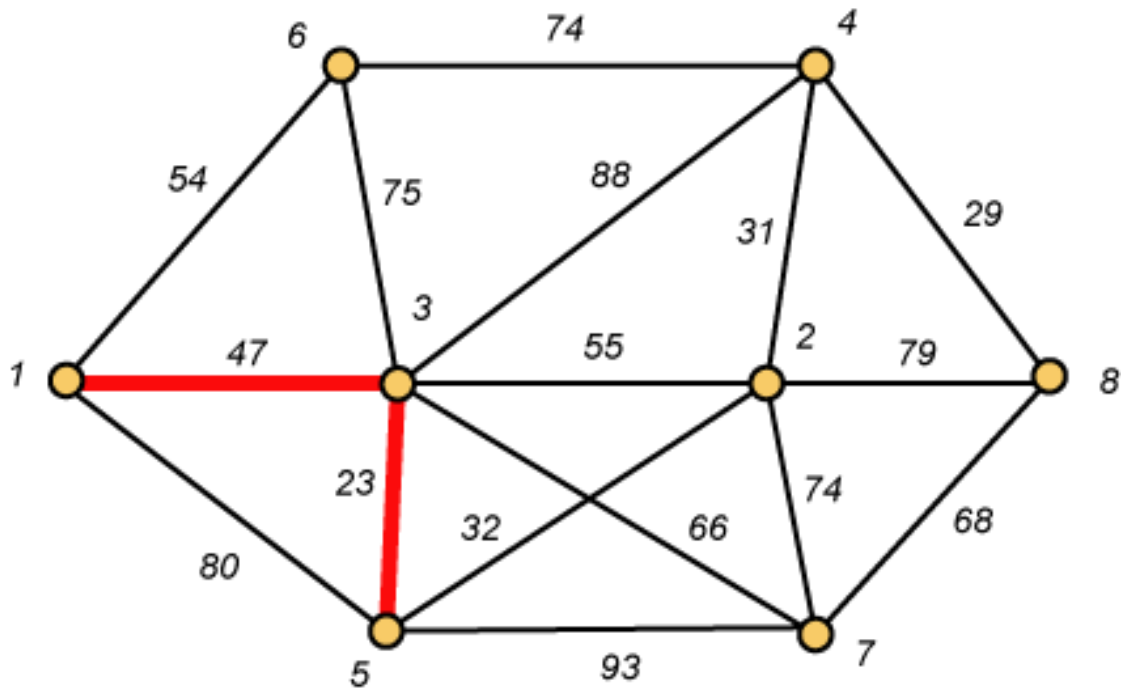

Prim – Step 3

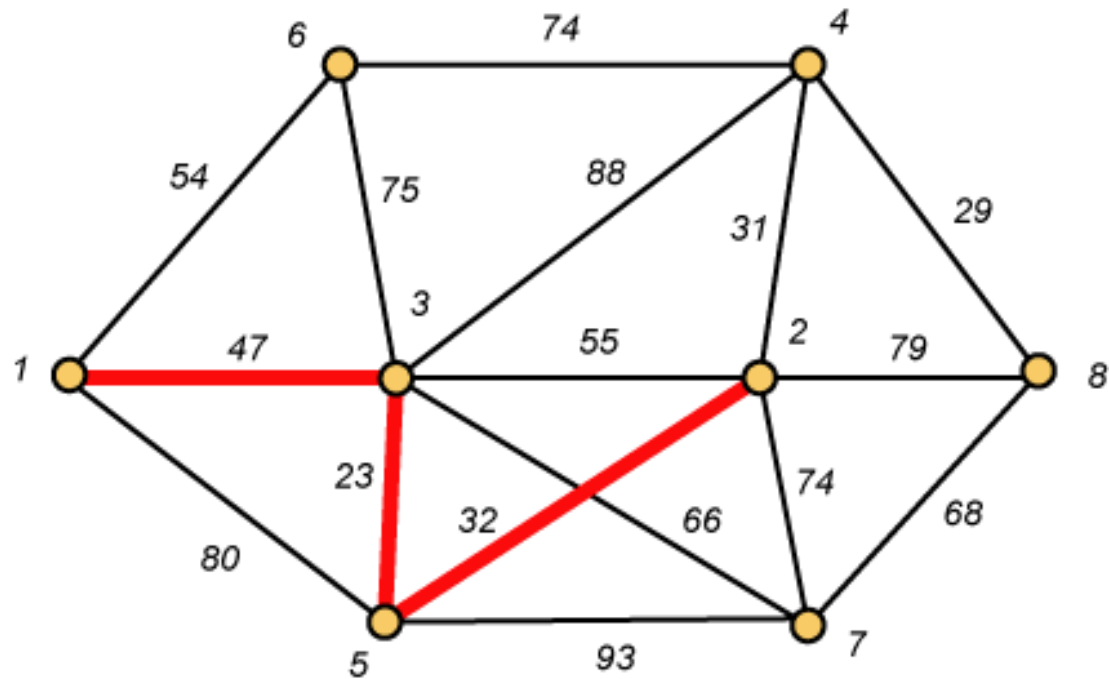

Prim – Step 4

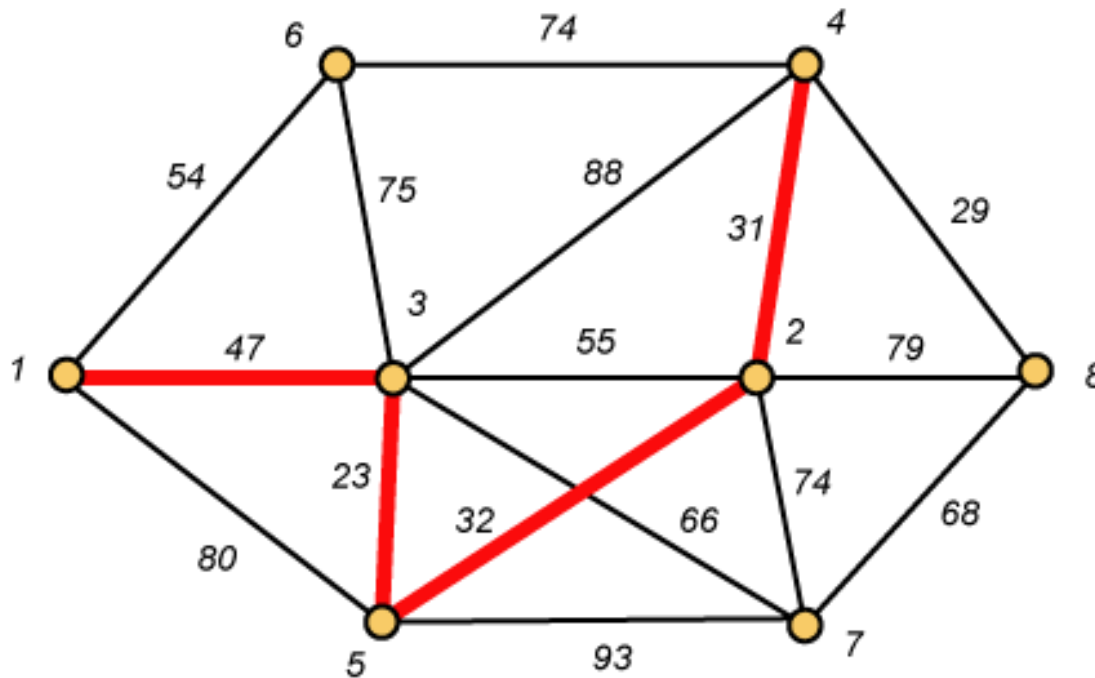

Prim – Step 5

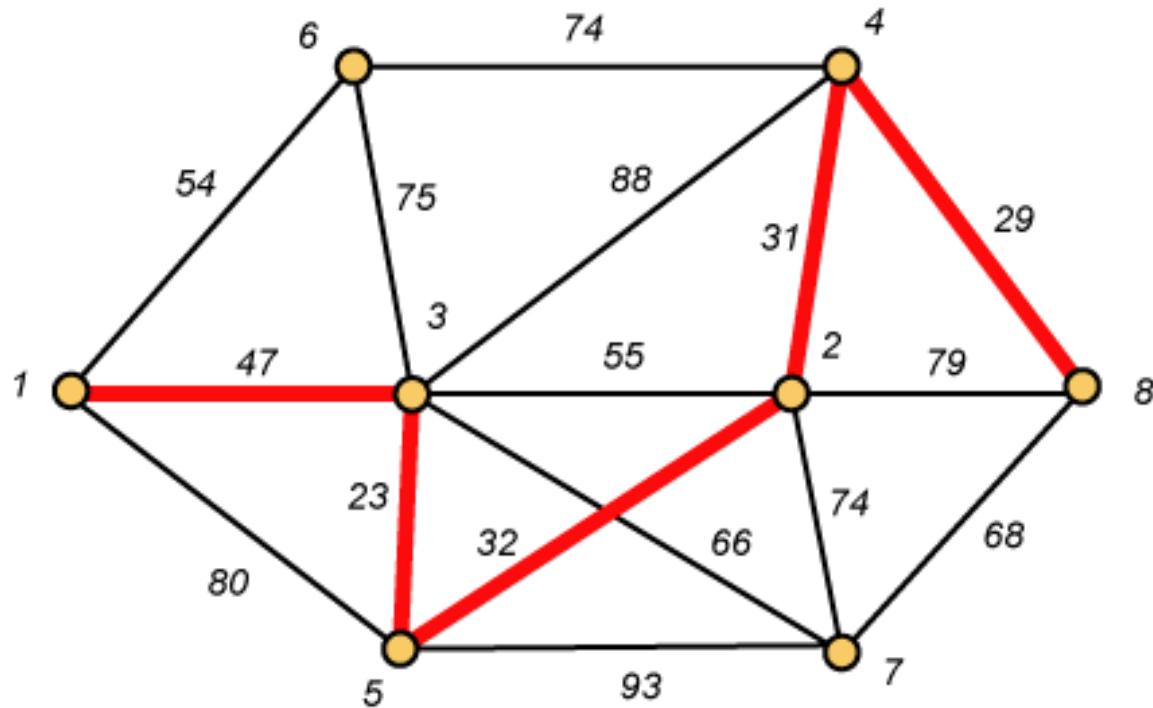

Prim – Step 6

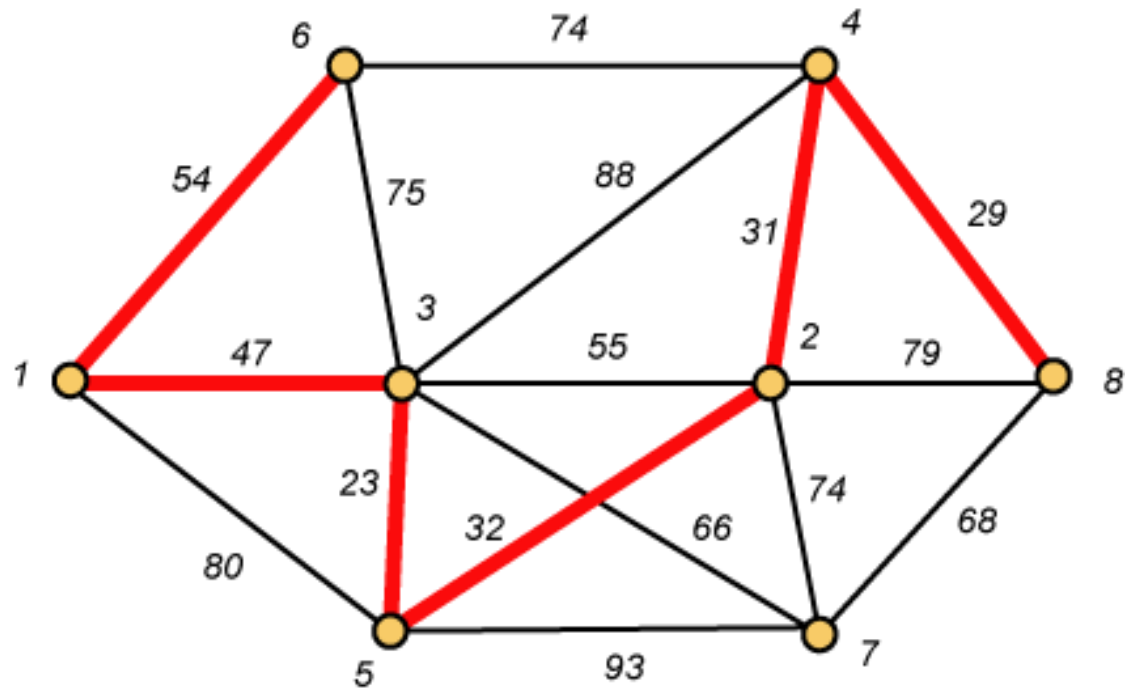

Prim – Step 7 *Done!!*

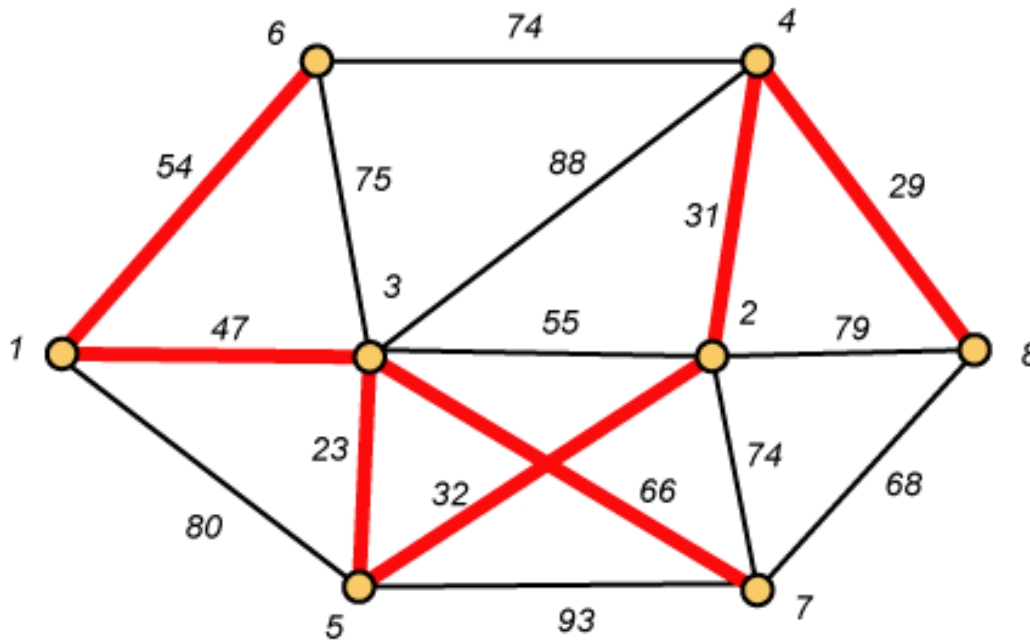

$$\text{Weight (T)} = 23 + 29 + 31 + 32 + 47 + 54 + 66 = \mathbf{282}$$

Prim Algorithm (2)

MST-Prim(G, w, r)

```
01  $Q \leftarrow V[G]$  //  $Q$  - vertices out of  $T$ 
02 for each  $u \in Q$ 
03      $key[u] \leftarrow \infty$ 
04  $key[r] \leftarrow 0$  //  $r$  is the first tree node, let  $r=1$ 
05  $\pi[r] \leftarrow NIL$ 
06 while  $Q \neq \emptyset$  do
07      $u \leftarrow \text{ExtractMin}(Q)$  // making  $u$  part of  $T$ 
08     for each  $v \in \text{Adj}[u]$  do
09         if  $v \in Q$  and  $w(u, v) < key[v]$  then
10              $\pi[v] \leftarrow u$ 
11              $key[v] \leftarrow w(u, v)$ 
```

Prim Algorithm: Variables

- r :
 - Grow the minimum spanning tree from the **root vertex “r”**.
- Q :
 - is a priority queue, holding all vertices that are **not in the tree** now.
- $\text{key}[v]$:
 - is the **minimum weight** of any edge connecting v to a vertex in the tree.
- $\pi [v]$:
 - names the **parent of v** in the tree.
- $T[v]$ –
 - Vertex v is **already included** in MST if $T[v]==1$, otherwise, it is not included yet.

The execution of Prim's algorithm (moderate part)

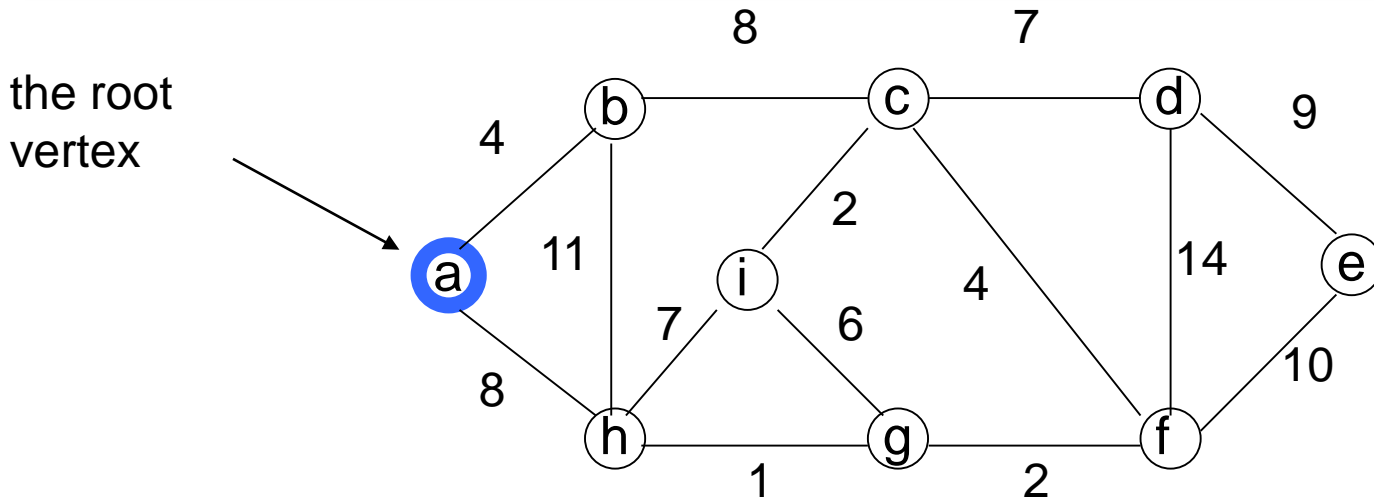

V	a	b	c	d	e	f	g	h	i
T	1	0	0	0	0	0	0	0	0
Key	0	-	-	-	-	-	-	-	-
π	-1	-	-	-	-	-	-	-	-

The execution of Prim's algorithm (moderate part)

the root vertex

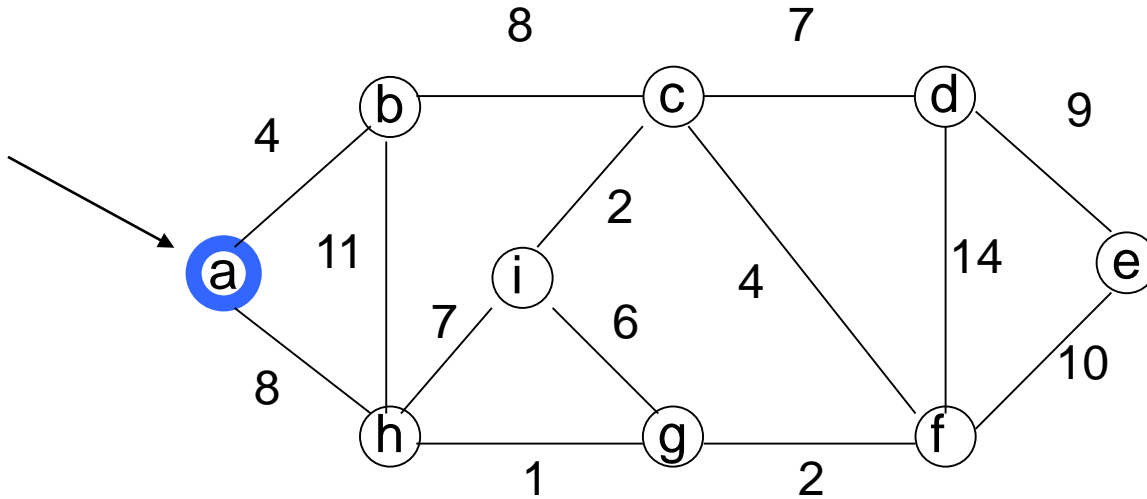

V	a	b	c	d	e	f	g	h	i
T	1	0	0	0	0	0	0	0	0
Key	0	4	-	-	-	-	-	8	-
π	-1	a	-	-	-	-	-	a	-



The execution of Prim's algorithm (moderate part)

the root vertex

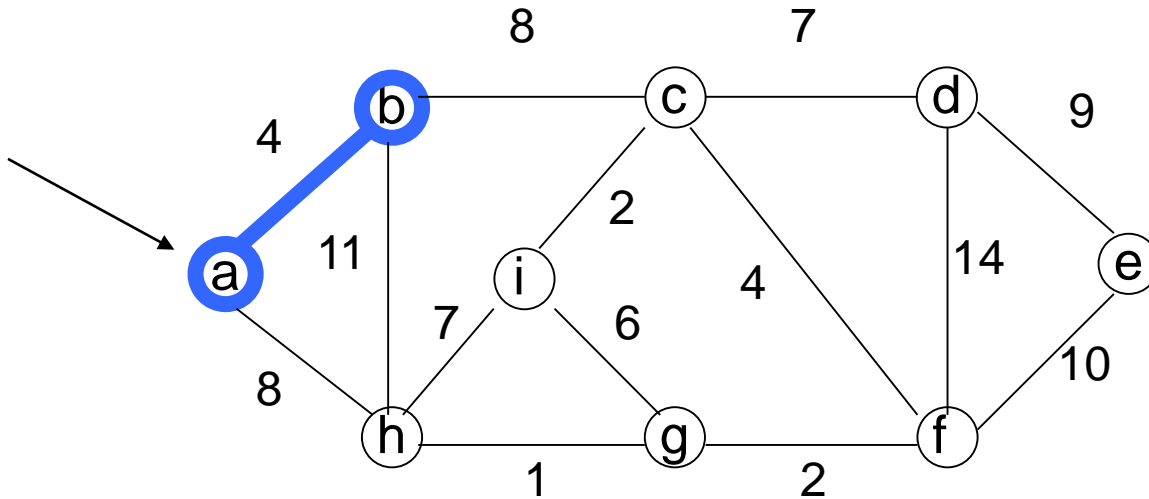

Important: Update $Key[v]$ only if $T[v]==0$

V	a	b	c	d	e	f	g	h	i
T	1	1	0	0	0	0	0	0	0
Key	0	4	8	-	-	-	-	8	-
π	-1	a	b	-	-	-	-	a	-



The execution of Prim's algorithm (moderate part)

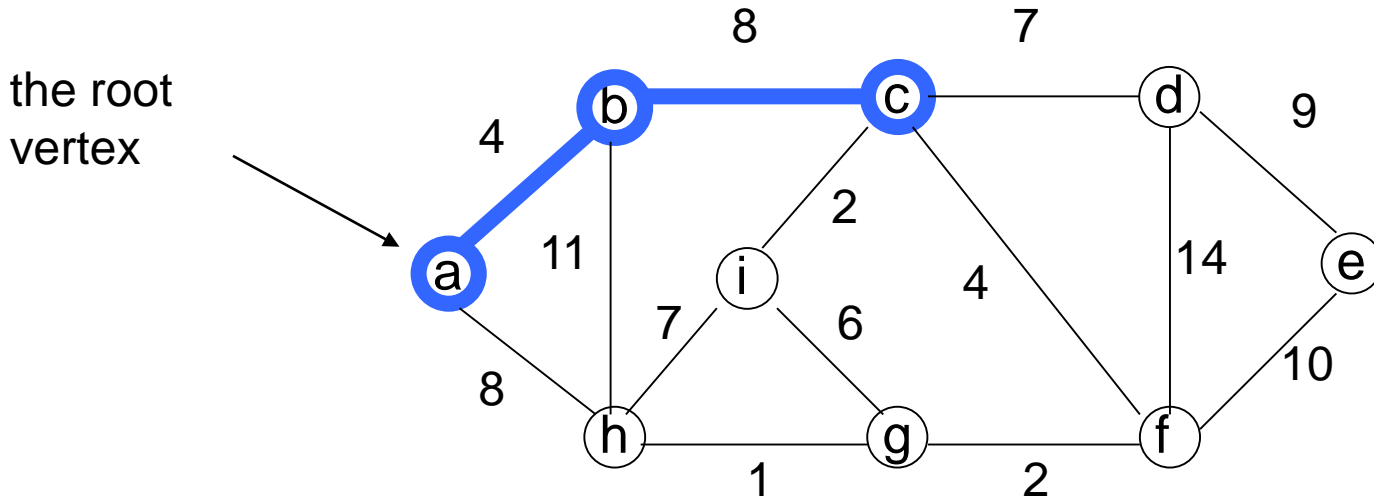

V	a	b	c	d	e	f	g	h	i
T	1	1	1	0	0	0	0	0	0
Key	0	4	8	7	-	4	-	8	2
π	-1	a	b	c	-	c	-	a	c



The execution of Prim's algorithm (moderate part)

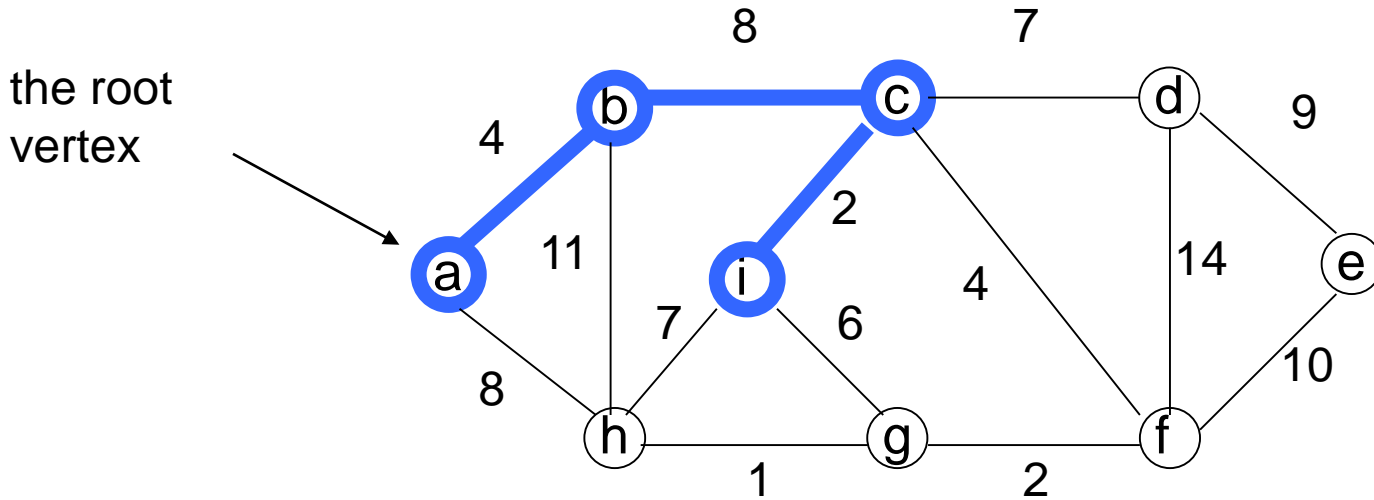

V	a	b	c	d	e	f	g	h	i
T	1	1	1	0	0	0	0	0	1
Key	0	4	8	7	-	4	6	7	2
π	-1	a	b	c	-	c	i	i	c



The execution of Prim's algorithm (moderate part)

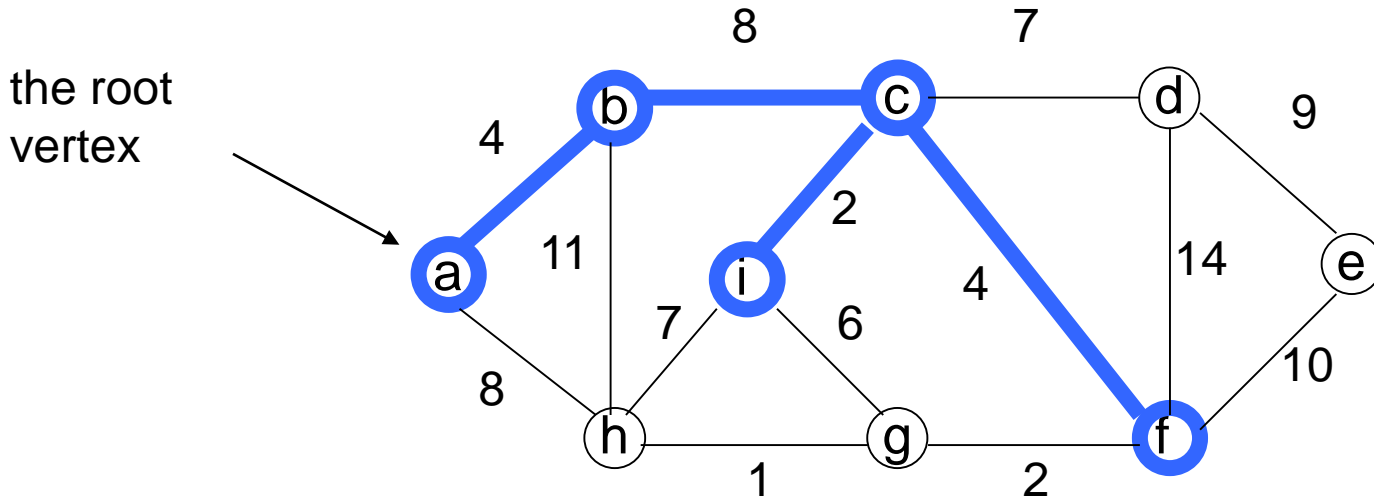

V	a	b	c	d	e	f	g	h	i
T	1	1	1	0	0	1	0	0	1
Key	0	4	8	7	10	4	2	7	2
π	-1	a	b	c	f	c	f	i	c



The execution of Prim's algorithm (moderate part)

the root vertex

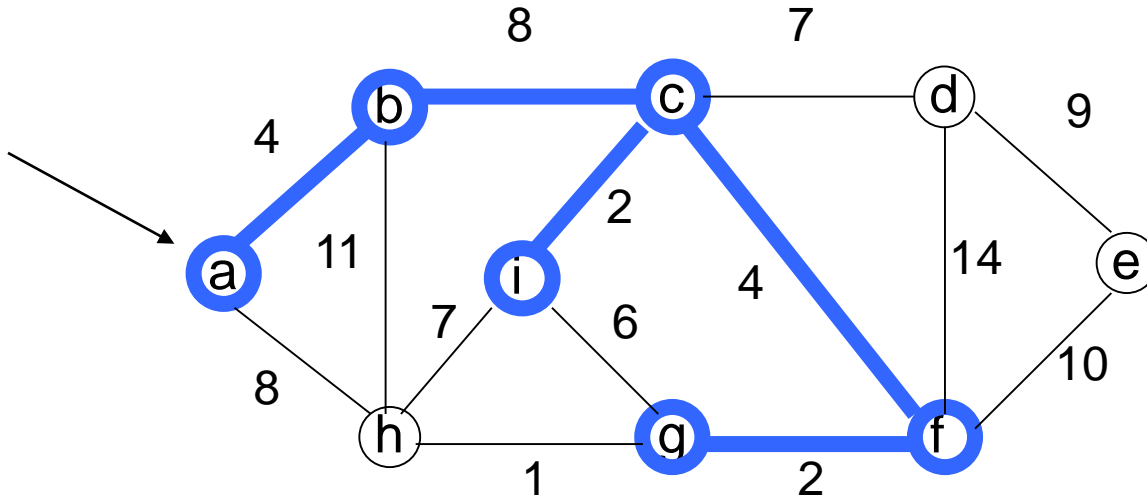

V	a	b	c	d	e	f	g	h	i
T	1	1	1	0	0	1	1	0	1
Key	0	4	8	7	10	4	2	1	2
π	-1	a	b	c	f	c	f	g	c



The execution of Prim's algorithm (moderate part)

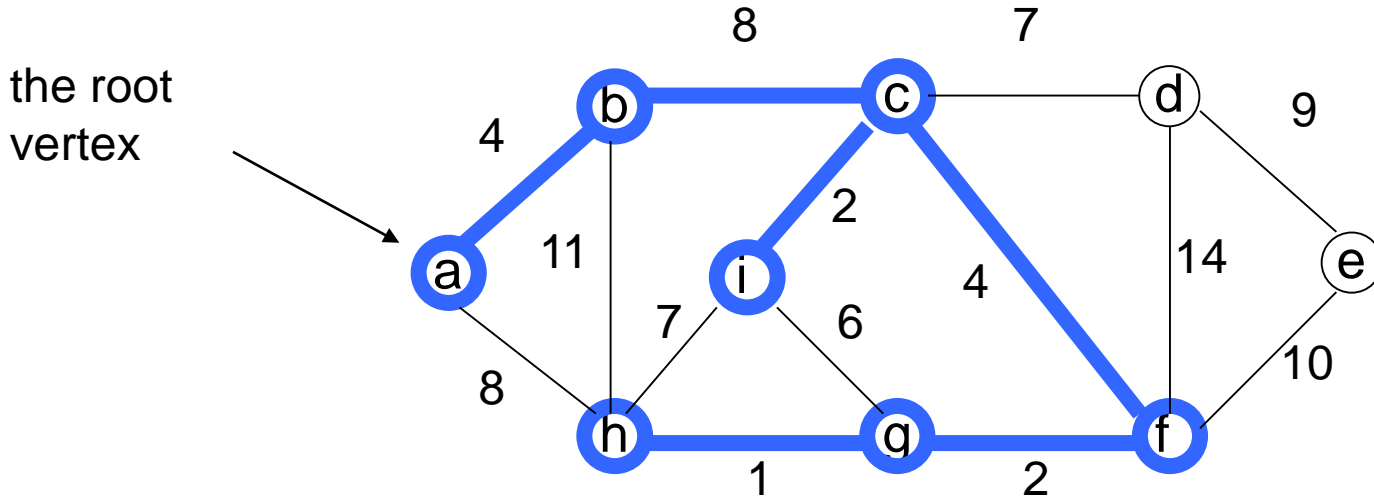

V	a	b	c	d	e	f	g	h	i
T	1	1	1	0	0	1	1	1	1
Key	0	4	8	7	10	4	2	1	2
π	-1	a	b	c	f	c	f	g	c



The execution of Prim's algorithm (moderate part)

the root vertex

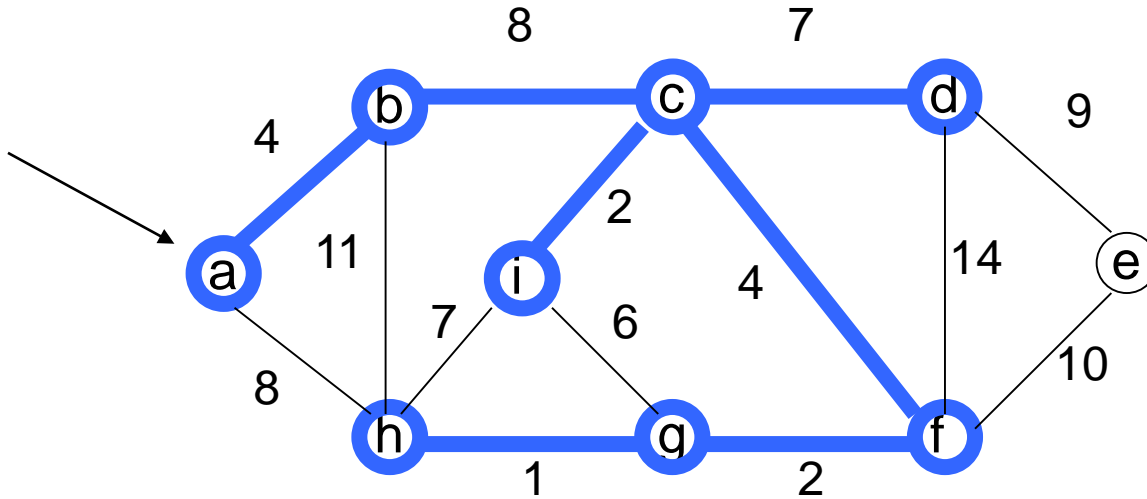

V	a	b	c	d	e	f	g	h	i
T	1	1	1	1	0	1	1	1	1
Key	0	4	8	7	9	4	2	1	2
π	-1	a	b	c	d	c	f	g	c



The execution of Prim's algorithm (moderate part)

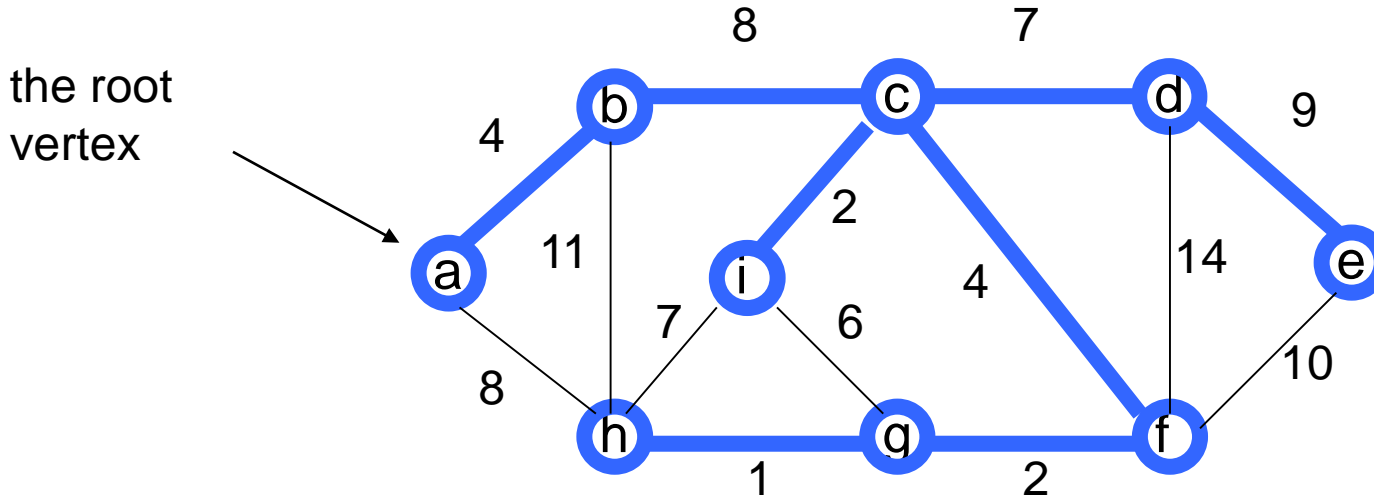

V	a	b	c	d	e	f	g	h	i
T	1	1	1	1	1	1	1	1	1
Key	0	4	8	7	9	4	2	1	2
π	-1	a	b	c	d	c	f	g	c

Complexity: Prim Algorithm

MST-Prim(G, w, r)

01 $Q \leftarrow V[G]$ // Q - vertices out of T

02 **for** each $u \in Q$

03 $key[u] \leftarrow \infty$

$O(V)$

04 $key[r] \leftarrow 0$

05 $\pi[r] \leftarrow \text{NIL}$

06 **while** $Q \neq \emptyset$ **do**

$O(V)$

07 $u \leftarrow \text{ExtractMin}(Q)$ // making u part of T Heap: $O(\lg V)$

08 **for** each $v \in \text{Adj}[u]$ **do**

Overall: $O(E)$

09 **if** $v \in Q$ and $w(u, v) < key[v]$ **then**

10 $\pi[v] \leftarrow u$

11 $key[v] \leftarrow w(u, v)$

Decrease Key: $O(\lg V)$

Overall complexity: $O(V) + O(V \lg V) + E \lg V = O(E \lg V)$

Overall Complexity Analysis

- $O(V^2)$
 - When we don't use heap
 - To find the minimum element, we traverse the “KEY” array from beginning to end
 - We use adjacency matrix to update KEY.
- $O(E \log V)$
 - When min-heap is used to find the minimum element from “KEY”.
- $O(E + V \log V)$
 - When fibonacci heap is used to find the minimum element from “KEY”.